



**FOR CLEANING SERVICE,
PROVIDES COMPREHENSIVE SOLUTIONS**



Vicando Commercial Products Co.,Ltd.
E-mail: vicando@163.com
www.vicando.hk

Vicando Commercial Products Co.,Ltd.

Committed to innovative product design, we provide you with comprehensive solutions to meet all your needs and create more value for you



HIGH QUALITY



HIGH EFFICIENCY



ERGONOMIC DESIGN

PROVIDE A PROFESSIONAL AND
EFFICIENT HOUSEKEEPING SERVICE

SOLUTION



ABOUT VICANDO

30+

Production Equipment

100+

Mold

Vicando Commercial Products Co., Ltd. is dedicated to offering superior and affordable products to luxury hotels and high-end establishments. We prioritize quality and service and have spent years developing innovative products such as housekeeping carts, waste management solutions, cleaning products, material transport equipment, and food service carts.

Vicando Commercial products Co., Ltd. has over 30 large-scale production equipment and over 100 sets of various moulds, providing a solid guarantee for our subsequent development with its powerful manufacturing and design capabilities. Our company's leaders possess extensive experience in sales and project management within the industry. They are committed to maximizing the benefits of both distributors and users, and are dedicated to providing sustainable products and solutions that promote the healthy development of the industry.

Our company is committed to advancing in the industry while adhering to the philosophy of progress. We stand by our distributors and users and prioritize green and environmentally friendly product manufacturing. We aim to contribute to the industry's growth and development actively.



Committed to innovative product design, we provide you with comprehensive solutions to meet all your needs and create more value for you

PHILOSOPHY

Vicando is a reliable partner for the hotel room service and cleaning industry, Providing an efficiently comprehensive solution.



Hyper Housekeeping Cart

03-05/ Hyper Housekeeping Cart	10-12/ Small room service trolley
06/ Optional Accessories	13-15/ Compact room linen trolley
07-09/ Quick Housekeeping Cart	



Front Office

18/ Hotel Luggage Cart	26/ Heavy duty Garment rack
19-24/ Specialty Luggage Cart	
25/ Luggage cart	





FRONT OFFICE

29-32/ Round Trash Can	40/ office trash cans
33-34/ Economy Classified Trash Can	41/ Guest Room Trash Can
35-37/ Step-on Container without Inner Barrel	42/ Ash/Trash Containers
38-39/ Slim Trash Can	



Cleaning

47-74/ Cleaning Tools	75/ Tool Holder Kit	80/ Caution floor sign
71/ Bath mats	76/ Mobile step stool	81-87/ Cleaning Cart
56/ Cleaning carry caddy	77-79/ Mop bucket	





Material Handling

89-92/ Cube truck	99-100/ Utility cart with side panel	104-105/ Heavy-duty utility cart
93-95/ Collapsible Laundry Cart	101-102/ room service cart	106-107/ Heavy-Duty Platform Truck
96/ X-Type Fabric Cart	103/ Food Warmer Caddy Storage Trolley	108-109/ Platform truck
97/ Fabric storage cart		



Transportation & Storage Product Line

111-112/ Baby high chair
113-114/ Baby Changing Station





HYPER HOUSEKEEPING CART

Innovative Product Design

Provide multifunctional and innovative design. A complete system solution for housekeeping .

Durable, Commercial-grade molded construction

Heavy-duty material, Easy to clean and smooth surface

Big Capacity

Offer exceptional storage space and adjustable middle shelf

Optional accessories

Offer optional accessories ,enhance functionality and productivity



HYPER HOUSEKEEPING CART





Hyper housekeeping cart

Vicando Hyper Housekeeping Cart is designed to improve hotel room cleaning efficiency with different accessories for enhanced functionality and productivity.

- ▶ The cart is quiet designed and equipped with silent non-marking wheels of two with brakes;
- ▶ Standard equipment includes plastic bags, bumper kit, a vacuum storage rack ;
- ▶ Large capacity cabinet can provide spacious storage space with an adjustable middle shelf;
- ▶ Ergonomically designed handle is easy to grab and control;
- ▶ Great design and easy to assembly;
- ▶ Bumper designed to reduce costly wall damage.



Efficient cleaning solutions

Convenient, efficient cleaning solutions designed to enhance your image and increase employee productivity.

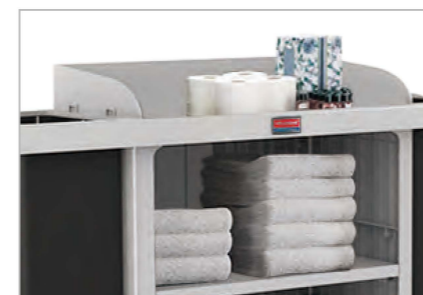

Flexible solutions

Room service carts come with a variety of accessories to choose from to help improve workflow and efficiency.



Excellent functional design

Compact design. Quiet casters, anti-collision design, Meet your needs in different places.



Durable materials

The product is made of high-quality and durable materials, strong and durable, Can withstand a variety of harsh conditions.

Hyper housekeeping cart



Item No.	Name	Size	Material	Color	Metric Capacity	PCS/CTN
HKC100	Standard Hyper Housekeeping Cart	1536 × 610 × 1252 mm	PP	Grey, Black	150 kg	1

Choose the optional accessories

Different optional accessories enhance functionality and productivity.



Optional accessories



Item No.	Name	Size	Material	Color	PCS/CTN
HC9P	9-pocket hanging bag	703 × 490 mm	Vinyl	Black	Pending
HCHBAG	Short bag	430 × 260 × 550 mm	Vinyl	Black	Pending
HCMBAG	Side-load mesh bag	430 × 260 × 820 mm	Mesh fabric	Black	Pending
HCBAG	High capacity vinyl bag	430 × 260 × 820 mm	Vinyl	Black	Pending
GC10	Garbage bag cover	460 × 290 × 3.5 mm	Cooking oil	Black	Pending
HCD	Divider	620 × 480 × 65 mm	ABS	Black	Pending
HCH	Hood	795 × 510 × 318 mm	PE	Grey, Black	Pending
HCDOOR	Locking door kit	440 × 760 mm	PE	Grey, Black	Pending

Small room service trolley

Compact room service trolley series is a specialized solution for small hotel room cleaning service, with large capacity and small footprint, aiming to improve the efficiency of cleaning service, with various cleaning tools, detergents, disposables and so on, so that the housekeeping staff can complete the room cleaning tasks quickly and effectively. It is also equipped with other practical features, such as storage space, garbage collection, etc., aiming to improve the efficiency and quality of hotel cleaning services. It provides a convenient and efficient working platform for cleaning staff, and at the same time enhances the customer's stay experience.

- ▶ Silent design with two universal casters
- ▶ Standard with a large-capacity environmental protection recycling bag, a small-capacity environmental protection recycling bag.
- ▶ Large capacity locker provides ample storage space.
- ▶ A durable, multi-purpose metal storage drawer in the center.
- ▶ Ergonomically designed handles for easy grip and control.
- ▶ Well-designed and easy to assemble.
- ▶ Topped with a sturdy and durable acrylic panel, it provides a spacious space.



Efficient Cleaning Solutions

Convenient, efficient cleaning solutions designed to enhance your image and improve employee efficiency



Flexible solutions

Room service carts are available with a wide range of accessories to help improve workflow and productivity.



Excellent appearance and functional design

Compact design. Quiet casters, impact resistant design, meets your needs in different places..



Durable materials

The products are made of high quality and durable materials that are rugged enough to withstand a wide range of harsh conditions.



Small room service trolley



ASSEMBLY REQUIRED



Top Cover Shelf
Sturdy and durable for all types of supplies

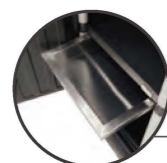

Metal Storage Drawer
Rugged and spacious



Optional storage bag
High quality cloth bag. Easily hold items



Silent wheels
Quiet wheels in motion. Smoother and quieter

Item No.	Name	Size	Color	PCS/CTN
JC08	Small room service trolley	1212x575x1320 mm	Black	1

Choose the optional accessories

Different optional accessories enhance functionality and productivity.



Top Cover



Multi-functional storage space

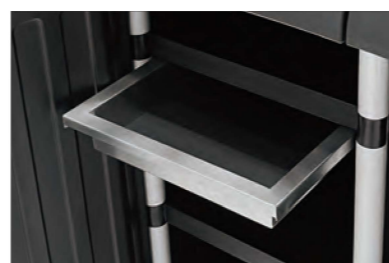

Multi-purpose stainless steel drawer



Compact room trolley

Room service trolley is a professional solution for efficient storage and flexible transportation of goods, strong load-bearing, stable and durable, small footprint, applicable to a variety of use scenarios. The modular design supports free adjustment of the height of the tier, which can be matched with various cleaning tools, disposables, cloths and grass, etc. to meet different needs. Open structure is easy to access, N-shaped handrail enhances stability, and high-quality universal pulley ensures smooth implementation. It integrates storage, sorting and flexible movement, helping to improve work efficiency and optimize the management process, allowing users to save energy and store items in a more tidy and orderly manner.

- ▶ Easily store all types of cloths, mineral water, paper towels and other items.
- ▶ Solid steel frame structure, stronger load-bearing capacity and higher stability.
- ▶ Thickened dense wire mesh design, solid wire diameter reinforcement, more storage space
- ▶ Easy to install, flexible adjustment of floor height according to demand
- ▶ Open design, easy to find items quickly Smooth and bright surface, easy to clean and maintain.
- ▶ High quality universal pulley, 360° flexible steering, smooth movement without noise.



Efficient Cleaning Solutions

Convenient, efficient cleaning solutions designed to enhance your image and improve employee efficiency



Flexible solutions

Room service carts are available with a wide range of accessories to help improve workflow and productivity.



Excellent appearance and functional design

Compact design. Quiet casters, impact resistant design, meets your needs in different places..



Durable materials

The products are made of high quality and durable materials that are rugged enough to withstand a wide range of harsh conditions.

Compact room trolley



Double-compartment Oxford cloth bag

Compartmentalized storage makes it easy to divide and categorize materials.



Adjustable floor height

Stronger load-bearing capacity, higher stability Not easy to be deformed, more peace of mind for long time use



High-capacity storage

Lightweight, durable and break resistant, chemically resistant and easy to clean



easy disassembly

Thickened stainless steel material, disassembly Removable design



Sturdy comfort grip

High-intensity, extended use environments Outstanding performance



Thickened wire mesh design

Solid wire diameter reinforcement, more storage space, carrying more possibilities



Reinforced columns

Stronger load-bearing capacity, higher stability Not easy to be deformed, more peace of mind for long time use



High quality universal pulley

360° flexible steering, smooth and noiseless movement

Item No.	Name	Size	Color	PCS/CTN
CLT100	Compact room trolley	1050 x 610 x 920 mm	silver	1



Quick housekeeping cart

The Quick Housekeeping Cart is a practical, efficient, and humane tool emphasizing confidentiality and privacy. It is designed to help housekeepers perform their room service duties more efficiently while providing guests an enhanced service experience. The suitcase-style structure enables housekeepers to move quickly between different floors and rooms, and the cart's large capacity and portable basket make it easy to find necessary items and improve work efficiency. The cart is also waterproof, oil-proof, and stain-proof, significantly extending its service life.

- ▶ The industry's most durable mobile cart solution that empowers staff to maintain areas discreetly and efficiently;
- ▶ Provide a premium guest experience, keeping the cleaning process hidden from view of guests;
- ▶ Easily move throughout the property with a lightweight, compact, and durable construction;
- ▶ Deliver a flexible solution, customizable for the unique needs of your property.

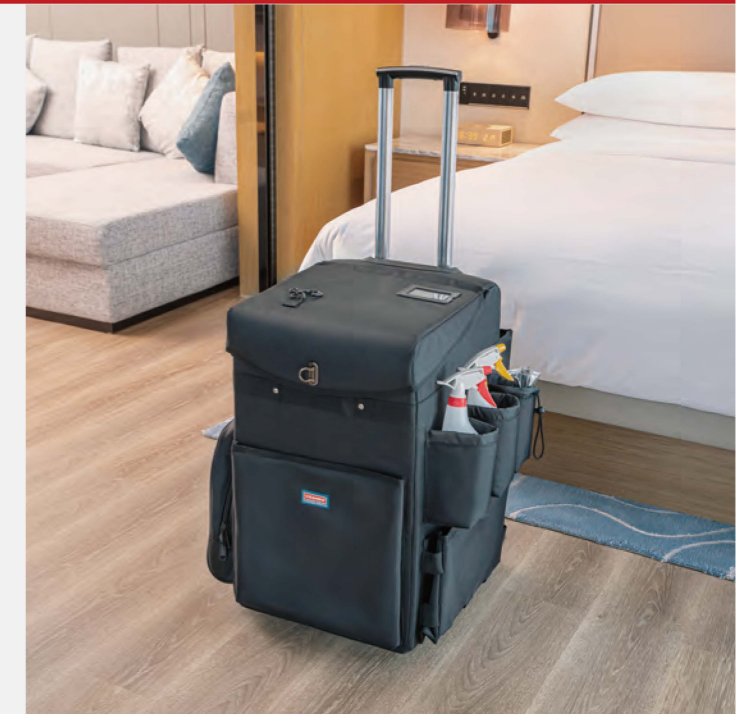

Efficient cleaning solutions

Efficient cleaning solutions designed to enhance your image and increase employee efficiency.

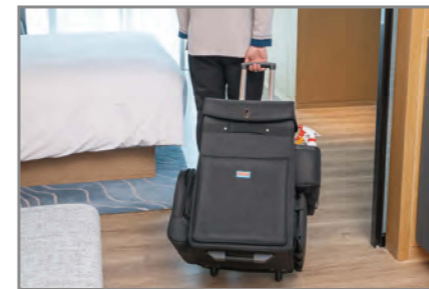

Excellent appearance design

The subtle design allow this cart to easily blend into upscale environments.



Durable and compact design

A durable aluminum telescoping handle combines with a compact design to provide comfortable navigation through tight spaces.



Multifunctional mobile mini-cart for housekeeping

Bring the tools and cleaning supplies needed for housekeeping to bring flexible solutions to your hotel to meet your specific needs.

Quick housekeeping cart



Repels Water, Oil, and Stains

Fabric protector helps maintain Quick Cart aesthetics and protects from rigorous daily use.



Removable Carry Caddy

Rigid dividers improve efficiency, keeping amenities and supplies organized.



Open state



Back side



Telescoping handle

Support plate with heavy-duty structure can prolong service life.



Secured Stick Goods

Heavy-duty fastening strap wraps around supplies to keep them secure while the cart is in motion.

Adjustable Dividers

Dividers can be moved or removed to create multiple compartments to meet your specific cleaning needs.

Item No.	Name	Size	Color	PCS/CTN
QC100	Quick housekeeping cart	560 × 510 × 630 mm	Black	1

Wellness Spa



LOBBY CART

LOBBY CART

High quality stainless steel

Adopt delicate polishing welding process, strong and firm, greatly enhance the load-bearing capacity of high hardness stainless steel material, high stability, anti-corrosion

High load-bearing capacity

High load-bearing capacity of the body, high rigidity, increased capacity

Wide range of applications

Hotel luggage trolleys are suitable for hotels, airports, exhibition halls and other places to meet the needs of different groups of people, types of luggage and environments, and to enhance service convenience and efficiency.

Multiple Solutions

We offer you a wide range of sizes, colors and materials. We can offer practical solutions for any area of your premises.



Hotel Luggage Cart

- Adopting exquisite polishing and welding process, strong and solid greatly enhanced
- Free customized carpet according to your preference
- Carpeted bottom and body to protect luggage from scratches.
- Strong load-bearing capacity of the body, high hardness, increased capacity

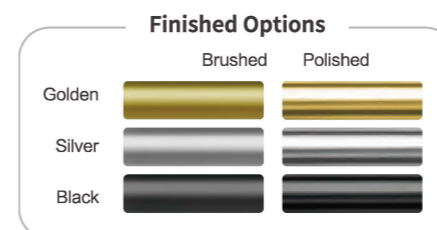

Item No.	Name	Size	Capacity	Material	Color	PCS/CTN
LC100	Hotel Luggage Cart	1240 × 580 × 1930 mm	37.9L/10Gal.	Stainless	Golden, Silver, Black	1



Specialty Luggage Cart

- High-quality stainless steel material, strong load-bearing
- Welding and polishing process, strong and solid
- Light sound wheels, the implementation of light sound smooth and quiet.
- Anti-bump strips to prevent collision damage to luggage and belongings.
- The floor is carpeted, which can prevent the luggage from being scratched and protect the luggage.



Finished Options

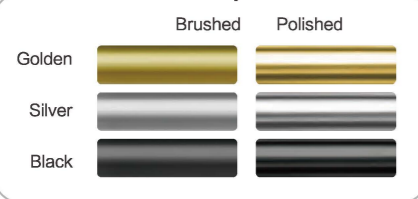

Carpeting Options



Specialty Luggage Cart

- High-quality stainless steel material, strong load-bearing
- Welding and polishing process, strong and solid
- Light sound wheels, the implementation of light sound smooth and quiet.
- Anti-bump strips to prevent collision damage to luggage and belongings.
- The floor is carpeted, which can prevent the luggage from being scratched and protect the luggage.



Finished Options

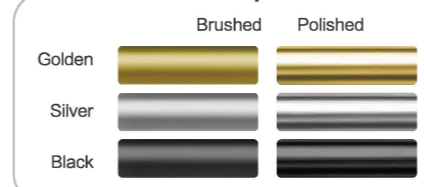

Carpeting Options



Item No.	Name	Size	Color	PCS/CTN
LCH110	Specialty Luggage Cart	1148 × 650 × 1835 mm	Golden, Silver, Black	1

Item No.	Name	Size	Color	PCS/CTN
LCH180	Specialty Luggage Cart	1118 × 650 × 1828 mm	Golden, Silver, Black	1



LOBBY CART

Specialty Luggage Cart

- High-quality stainless steel material, strong load-bearing
- Welding and polishing process, strong and solid
- Light sound wheels, the implementation of light sound smooth and quiet.
- Anti-bump strips to prevent collision damage to luggage and belongings.
- The floor is carpeted, which can prevent the luggage from being scratched and protect the luggage.

Finished Options

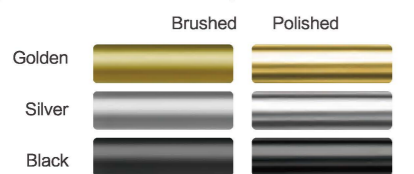

Carpeting Options



Luggage cart

- Constructed of stainless steel for durability, it can be heavily utilized in busy hospitality environments.
- Suitable for a variety of applications including hotels, apartments, hospitals, sports arenas, gyms and more,
- The cart's contemporary design features a sleek and stylish look that adds sophistication to any room while.

Available colors

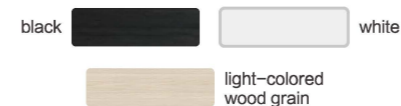

Carpeting Options



Stainless steel
Sturdy and durable

crashworthiness
Anti-bump rubber design on all sides

Item No.	Name	Size	Color	PCS/CTN
LC200	Specialty Luggage Cart	1200 × 700 × 1828 mm	Golden, Silver, Black	1

Item No.	Name	Size	Color	PCS/CTN
LC300	Luggage cart	1170 × 550 × 1900mm	Golden, Silver, Black	1





Luggage cart

- High hardness titanium stainless steel material, high stability, anti-corrosion
- Bumper strip design is beautiful, delicate and generous, to prevent collision damage to the goods
- Carpeted bottom and body to protect luggage from scratching
- New material wheels are smoother and quieter in the process of using.



Item No.	Name	Size	Color	PCS/CTN
PLC66	Specialty Luggage Cart	1100 × 645 × 995 mm	Golden, Silver, Black	1

Luggage cart

- High hardness titanium stainless steel material, high stability, anti-corrosion
- Bumper strip design is beautiful, delicate and generous, to prevent collision damage to the goods
- Carpeted bottom and body to protect luggage from scratching
- New material wheels are smoother and quieter in the process of using
- Hidden wheels for beautiful design.

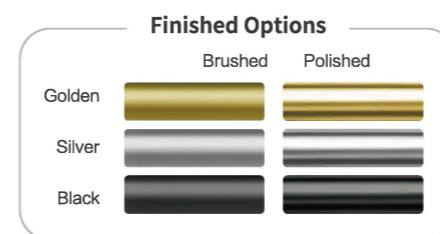

Item No.	Name	Size	Color	PCS/CTN
PLCH32	Specialty Luggage Cart	1100 × 645 × 995 mm	Golden, Silver, Black	1



LOBBY CART





Luggage cart

- High hardness titanium stainless steel material, high stability, anti-corrosion
- Bumper strip design is beautiful, delicate and generous, to prevent collision damage to the goods
- Carpeted bottom and body to protect luggage from scratching
- New material wheels are smoother and quieter in the process of using.



Stainless steel
Sturdy, durable and stable

Silent wheels
Quiet and easy to implement



Item No.	Name	Size	Color	PCS/CTN
PLC54	Specialty Luggage Cart	500 × 400 × 1220 mm	Golden, Silver, Black	1

Heavy duty Garment rack

- Made of high quality stainless steel, carefully polished, smooth texture
- Mute brake wheels, easy to move
- Strong load-bearing capacity, to meet the needs of multi-hanging
- Mute directional wheels, wear-resistant and easy to push



GC120



GC160

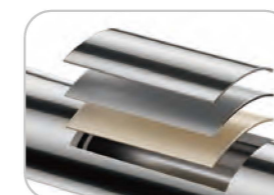

Stainless steel
Sturdy, durable and stable



GC260

Item No.	Name	Size	Color	PCS/CTN
GC120	Heavy duty Garment rack	1220 × 600 × 1700mm	Stainless Steel	Pending
GC160	Heavy duty Garment rack	1630 × 560 × 1790Hmm	Stainless Steel	Pending
GC260	Heavy duty Garment rack	2600 × 750 × 800mm	Stainless Steel	Pending





Utility And Recycling Refuse

Perfect Waste Management System

We provide a highly efficient, low-cost waste management system. Our products are made of high quality material with a sturdy structure to prolong their life.

Sustainable Development

All our plastic containers are 100% recyclable.

Cost-Efficient

Our waste collection and transport solutions offer productivity gains—reducing the time taken for repetitive tasks.

Multiple Solutions

We provide products of various sizes, colors and materials, designed to deliver practical waste solutions for diverse areas across the workplace.



UTILITY AND RECYCLING REFUSE

ROUND TRASH CAN

Proprietary design constructed with the highest quality material plus a UV inhibitor ensures long life in even the most extreme commercial environments. Guaranteed to never fade, warp, crack, or crush.



Round trash Can Lid



Bag cinches

Secure liners allowing for knot-free liner

Seamless construction

Helps make cleaning easier.

Rounded handles

Venting channels

Make removing liners, improving productivity and reducing the risk of injury.

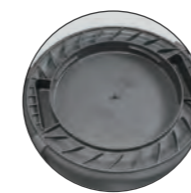

Reinforced base

Round trash Can Dolly



Twist lock

Casters



Sorted Recycling



Multiple Colors Available



Eco-friendly tasteless



Tough material



Imported quality



Large capacity





Round Trash Can

- Never rust, concave and peel off;
- The sealed lid makes no leakage;
- Strengthened edge makes it more durable;
- Rely on them for all your storage and processing needs;
- Well-designed handles make easier and more comfortable work;
- Double surrounding edges at the bottom improve the stability and enhance the dragging force .



Durable and strong trash can, Made of PE material by injection mould.



This durable trash container resists dents and does not fade, warp, or crack with continuous use for all environment.

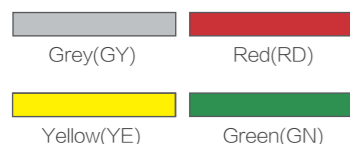

Item No.	Name	Size	Capacity	Material	Color	PCS/CTN
R038	37.9L Round Trash Can	Φ398 × 434 mm	37.9L/10Gal.	PE	GY	12
R076	75.7L Round Trash Can	Φ492 × 584 mm	75.7L/20Gal.	PE	GY	12
R120	121.1L Round Trash Can	Φ557 × 693 mm	121.1L/32Gal.	PE	GY,RD,YE,GN	6
R166	166.5L Round Trash Can	Φ617 × 794 mm	166.5L/44Gal.	PE	GY	6
R208	208.2L Round Trash Can	Φ679 × 840 mm	208.2L/55Gal.	PE	GY	6

Round trash can lid

- Self-draining channels prevent water from pooling, reducing still water buildup;
- Snap-lock ensures a secure fit;
- Ridges enable stacking containers to provide a space-efficient storage solution.



RC01

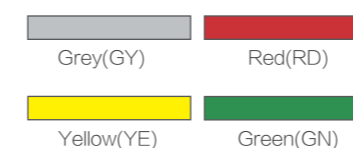

Item No.	Name	Size	Material	Color	PCS/CTN
RC01	37.9L Round Trash Can	Φ410 × 28 mm	PP	GY	12
RC02	75.7L Round Trash Can	Φ500 × 40 mm	PP	GY	6
RC03	121.1L Round Trash Can	Φ570 × 38 mm	PP	GY,RD,YE,GN	6
RC04	166.5L Round Trash Can	Φ633 × 38 mm	PP	GY	6
RC05	208.2L Round Trash Can	Φ690 × 49 mm	PP	GY	12

Round trash can dolly

- Easy mobility and maneuverability of heavy loads;
- Swivel castors make transport easily;
- Attach trash containers with ease;
- Sturdy structural foam construction won't rust, dent, chip, or peel;
- Round bin carts are not suitable for R038.



Item No.	Name	Size	Material	Color	Metric Capacity	PCS/CTN
RTCD	Round trash Can Dolly	Φ460 × 164 mm	PP	Black	120 kg	2





Economy Classified Trash Can

- Boasting a sturdy, injection-molded virgin high-density polyethylene construction;
- Non-slip handle for easy pushing and pulling;
- Easy to open the lid and move, when you throw away the garbage, close the lid in time. Keeps out bacterial odors;
- Reinforced corners around the bucket for added longevity;
- Heavy-duty wheels that reduce user stress and fatigue with effortless maneuverability over steps and curbs;
- 2 metal support rods, easy to open the lid.

Durable handle

Easy to open the lid and move, when you throw away the garbage, close the lid in time. Keeps out bacterial odors

Reinforcement around the barrel

Reinforced corners around the bucket for added longevity

Metal support rods

2 metal support rods, easy to open the lid

Durable Construction

Boasting a sturdy, injection-molded virgin high-density polyethylene construction

Moves Easily

heavy-duty wheels that reduce user stress and fatigue with effortless maneuverability over steps and curbs.



Item No.	Name	Size	Capacity	Material	Color	PCS/CTN
TC120	Economy Classified Trash Can	550 × 470 × 950 mm	120L	PE	RD,BU,GN,GY	1
TC240	Economy Classified Trash Can	725 × 590 × 1090 mm	240L	PE	RD,BU,GN,GY	1



GARBAGE BIN SERIES





Step-on Container

Slim profile and small footprint maximize space to fit in the tightest spaces.



Avoid touching

The durable pedal and lifer ensure quick and reliable operation.



Tight-fitting and Overlapping lid

Prevent odors and bacteria from spilling and spreading



Tough and Durable

All-plastic construction won't rust or chip and it is tough and puncture-resistant.

Step-on container

- Provides easy access to the container without the need to lift;
- The sealed lid can prevent odor from spilling;
- Tough, puncture-resistant, all-plastic construction won't rust or damage;
- Heavy pedal for hands-free use, avoiding cross infection.

* Inner tube not included, inner tube needs to be purchased separately



Item No.	Name	Size	Capacity	Material	Color	PCS/CTN
STP30	30L Step-on Container	400 × 380 × 440 mm	30.3L/8Gal.	HDPE+PP	Beige	4
STP45	45L Step-on Container	400 × 380 × 600 mm	45.4L/12Gal.	HDPE+PP	Beige	3
STP68	68L Step-on Container	500 × 400 × 670 mm	68.1L/18Gal.	HDPE+PP	Beige	3
STP87	87L Step-on Container	500 × 400 × 840 mm	87.1L/23Gal.	HDPE+PP	Beige	2

Inner barrel

- Helps prolong the life of your containers;
- Durable plastic construction with smooth surfaces for easy cleaning.

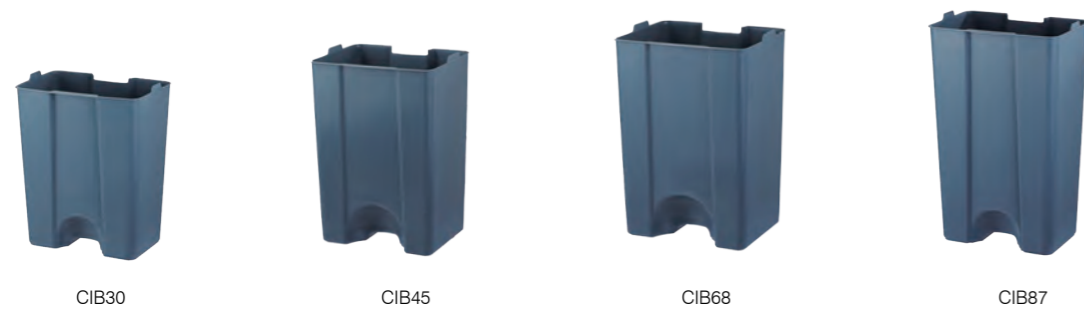

Item No.	Name	Size	Capacity	Material	Color	PCS/CTN
CIB30	30L Inner Barrel	354 × 288 × 350 mm	30.3L	PP	Grey	6
CIB45	45L Inner Barrel	354 × 288 × 516 mm	45.4L	PP	Grey	6
CIB68	68L Inner Barrel	453 × 300 × 574 mm	68.1L	PP	Grey	6
CIB87	87L Inner Barrel	453 × 300 × 736 mm	87.1L	PP	Grey	6



GARBAGE BIN SERIES



Slim trash can

- With a unique design, cross-ventilation is created inside and this makes easier dumping;
- The buckles fasten the garbage bags;
- Handles on both sides make easier job;
- It can be conveniently transported with a dolly.



The buckles fasten the garbage bags. Handles on both sides make easier job.



Bottom handle design makes it easier to operate when you are dumping trash



Ventilated design saves
60% pull out strength



SLIM76



SLIM76C



SLIM76D

Item No.	Name	Size	Capacity	Material	Color	Metric Capacity	PCS/CTN
SLIM76	76L Slim Trash Can	566x279x760 mm	76 L	PE	Grey	/	6
SLIM76C	Slim Trash Can Lid	557x297x140 mm	/	PP	Black	/	6
SLIM76D	Slim Trash Can Dolly	580x309x195 mm	/	PP	Black	75 kg	1



Office trash can

- Multi-bucket separation, effective classification
- Separate lid, not easy to cascade odor
- Flexible footrest, easy to step on
- Anti-slip base can increase the friction between the trash can and the ground



OTC01



OTC02



OTC03

Item No.	Name	Size	Capacity	Color	PCS/CTN
OTC01	Office trash can(single compartment)	283 × 169 × 402mm	8L	black silver gold	4
OTC02	Office trash can(double compartment)	310 × 310 × 400mm	2x8L	black silver gold	1
OTC03	Office trash can(three compartments)	460 × 265 × 400mm	3x8L	black silver gold	1



GARBAGE BIN SERIES





Guest Room Trash Can

- Hydraulic Slow Lowering Silent Opening and Closing
- Double-layered garbage bags inside and out
- Thick stainless steel enameled anti-fingerprint technology
- Anti-fingerprint technology, easy to carry, dirt-resistant, easy to change the bag



RTCR5



RTCE6



RTCS6

Item No.	Name	Size	Capacity	Color	PCS/CTN
RTCR5	Guest Room Trash Can	203 × 280mm	5L	black silver gold	4
RTCE6	Guest Room Trash Can	140 × 270 × 330mm	6L	black silver gold	4
RTCS6	Guest Room Trash Can	280 × 210 × 300mm	6L	black silver gold	3

Ash/Trash Containers

- Fashionable appearance High-end atmosphere, suitable for a variety of occasions
- Large-capacity stainless steel inner barrel, fire-retardant, long service life
- Preferred stainless steel material, corrosion-resistant, acid and alkali resistant
- Separate design of inner and outer barrels, independent design, flexible access to the inner barrel.



MS235



ACR28



ACS38

Item No.	Name	Size	Color	PCS/CTN
ACS38	Ash/Trash Containers	350 × 350 × 800 mm	Black+Stainless Steels	1
ACR28	Ash/Trash Containers	280 × 1000 mm	Black	1
MS235	Metal Signboard	260 × 320 × 580 mm	Black gold	1



Cleaning

Simple, fast and effective, use product cleaning solution!

Provide a wide range of service solutions,
Reduce waste and increase employee productivity,
and optimize space sanitation in a sustainable way.
Ensures reduced costs, improved functionality and hygiene.

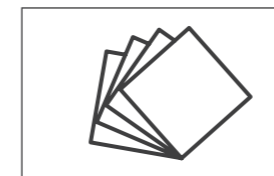

Surface cleaning

Effectively cleans a variety of surfaces and hard-to-reach corners and high areas.

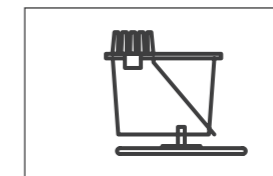

Floor cleaning

A complete range of commercial cleaning products for hard floors and carpets.



Duct cleaning

Suitable for cleaning dirt on the outer wall of pipes, etc.

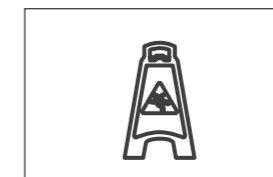

Floor Safty Signs

Lightweight ,versatile signs for effective safety communication



Dust Mop Selection Guide

There are several important factors to consider when choosing a dust mop. Use the guidelines on the following pages to choose the best dust mop for your floor care needs.

Environment	Best	Better	Good
Hospitality	Microfiber Dust Mop	Synthetic fiber dust pusher	Mixed fiber dust pusher
Foodservice	Microfiber Dust Mop	Synthetic fiber dust pusher	Mixed fiber dust pusher
Healthcare facilities	Microfiber Dust Mop	Mixed fiber dust pusher	Synthetic fiber dust pusher
Industrial and commercial	Microfiber Dust Mop	Synthetic fiber dust pusher	Mixed fiber dust pusher
Educational facilities	Microfiber Dust Mop	Synthetic fiber dust pusher	Synthetic fiber dust pusher
Office buildings	Microfiber Dust Mop	Synthetic fiber dust pusher	Mixed fiber dust pusher

Mop Construction Features

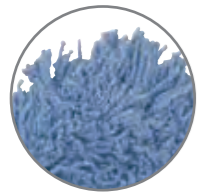

Twisted-Loops

Highly effective at capturing dust and dirt. Premium Twisted Loops are less prone to snags, frays, and unraveling during cleaning and laundering.

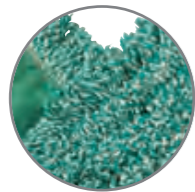

Looped Ends

Reduce fraying and depleting for better durability and longer product life. More effective than cut-end mops.



Cut Ends

Economical construction for general-purpose dusting.



Reinforced Stitching

Reinforced, double-needle stitching at key "wear" points increases product life.

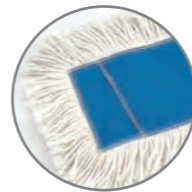

Backing Design

Slip-on/slide-off backing allows quick, easy setup for standard or breakdown mop frames.

Laundryability

The laundryability of a mop is based on the number of commercial washing and drying cycles. It can withstand before the construction of the mop is degraded or the performance declines. Microfiber, synthetic, and blended fiber mops have the highest levels of laundryability.

Durability

The durability of a mop is a measure of how long it will perform before needing to be replaced. Microfiber, synthetic, and blended fiber mops are the most durable. Mops with antimicrobial fibers have greater durability because they inhibit the bacterial growth that causes mop odor and discoloration.

Dust Pickup

Dust pickup is the ability of a mop to remove dust and dirt from the floor surface. Microfiber, blended fiber, and synthetic mops have the highest degree of dust pickup.

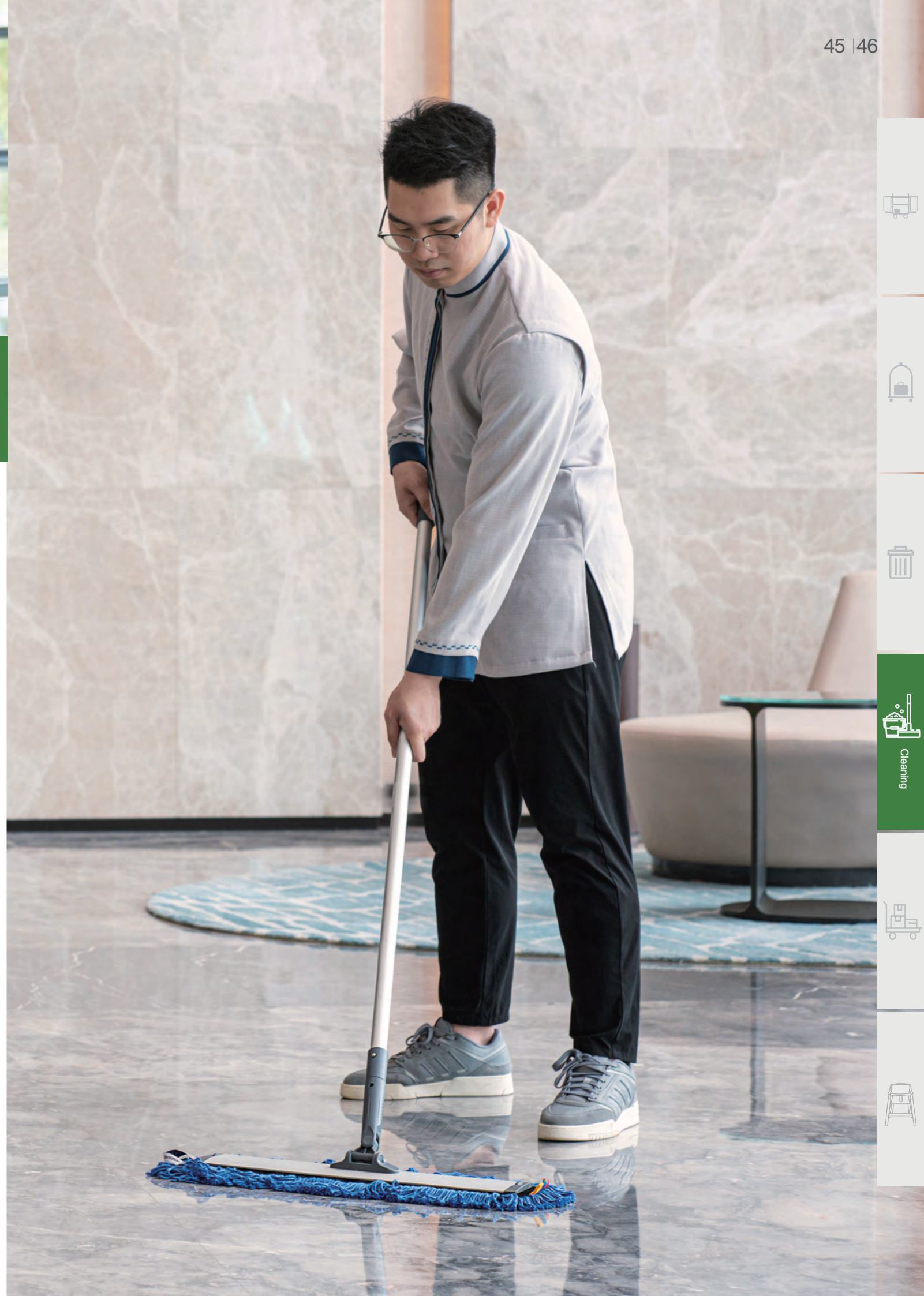

Cleaning





Dust Mop characteristic



Healthy

By removing dirt and bacteria



Productivity

Proven to increase mopping speed and reduce user effort



Sustainability

Save resources by reducing water and chemical consumption

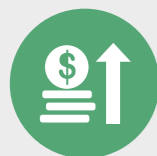

Cost

Reduced usage costs based on pre-watering and ensuring good cleaning effect



High quality

High-quality fibers ensure surfaces dry quickly without streaks or smudges

Microfiber Dust Mops

- Dust mop with whisker edges has better ability to clean dust and debris;
- Characterized by good stain removal and water absorbency;
- The cleaning area is greatly increased, increasing the surface area by 50%, compared with Whiskerless dust mop cleans faster

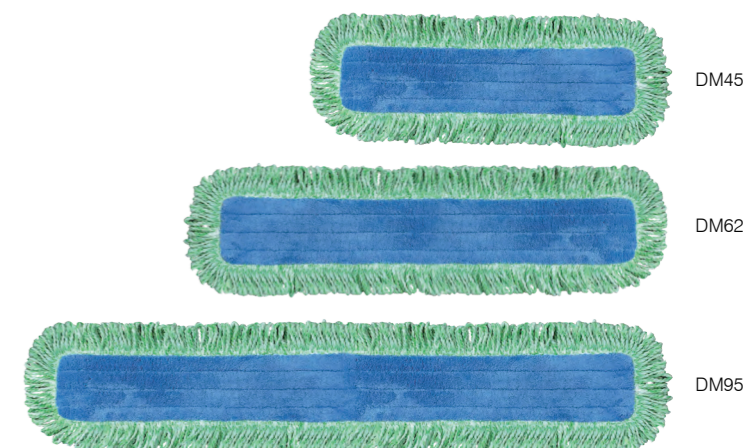

Item No.	Name	Size	Color	PCS/CTN
DM45	Microfiber Dust Mops	580x230 mm	Blue	50
DM62	Microfiber Dust Mops	780x230 mm	Blue	50
DM95	Microfiber Dust Mops	1050x230 mm	Blue	50

Microfiber dust mop

- 100% microfiber Damp mop provide the great cleaning for floor;
- Scrubbing strips for cleaning tough, dried-on Stains.



Item No.	Name	Size	Color	PCS/CTN
6045	Microfiber Dust Mop	490 × 130 mm	Blue	50
6062	Microfiber Dust Mop	690 × 130 mm	Blue	50
6095	Microfiber Dust Mop	950 × 130 mm	Blue	100



Cleaning



Dust Mop

- Prelaundered and preshrunk;
- Launderable for long product life;
- Slip-on backing for easy setup.



Item No.	Name	Size	Color	PCS/CTN
7060	Slip-on Backing Dust Mop	660 × 168 mm	White	40
7090	Slip-on Backing Dust Mop	970 × 168 mm	White	30
7011	Slip-on Backing Dust Mop	1180 × 168 mm	White	25

Dust mop

- Perfectly dust mop for cleaning tough, dried-on stains;
- With pre-washing and preshrunk treatment;
- Bleach-safe and proven to last longer and provide better cleaning
- Back adhesive strip design make easy to install.

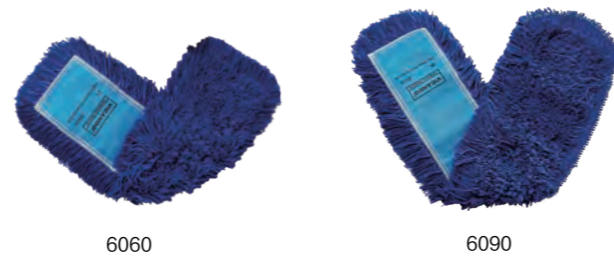

Item No.	Name	Size	Color	PCS/CTN
6060	Dust Mop	660 × 168 mm	Blue	24
6090	Dust Mop	970 × 168 mm	Blue	24

Dust mop handle and frames

- Heavy-duty metal frame for durable performance;
- Corrosion-resistant metal pole.

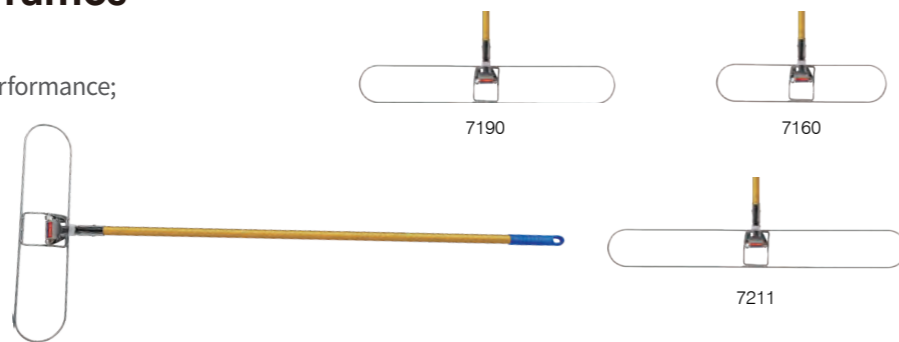

Item No.	Name	Size	Color	PCS/CTN
7160	Dust Mop Handle and Frames	L580 mm	Black	150
7190	Dust Mop Handle and Frames	L880 mm	Black	150
7211	Dust Mop Handle and Frames	L1060 mm	Black	150



Alumium mop holder frame

- Quick-connect frames feature a flat profile that slides easily under furniture and equipment;
- Trapezoidal shape improves cleaning in corner and other hard-to-reach areas;
- Lightweight aluminum construction;
- Replaceable hook and loop strips attach all damp and dust mops;
- Plastic end caps help protect walls and furniture.

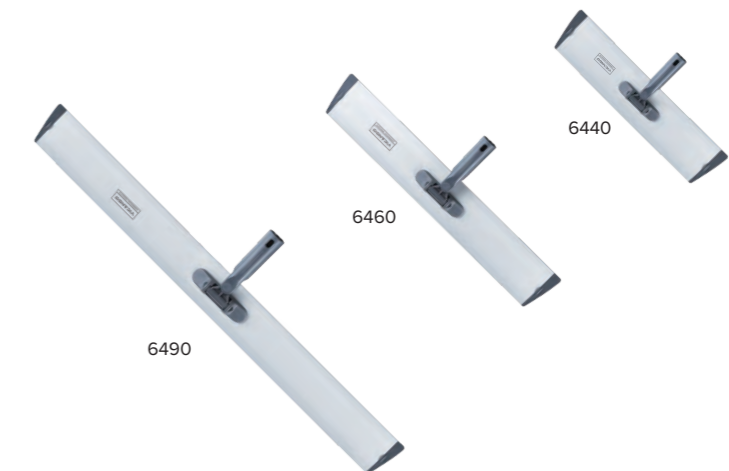

Item No.	Name	Size	Color	PCS/CTN
6440	Alumium Mop Holder Frame	400 × 90 mm	Silver	50
6460	Alumium Mop Holder Frame	550 × 90 mm	Silver	50
6490	Alumium Mop Holder Frame	850 × 90 mm	Silver	25



Alumium handle

- Light weight construction, reduce labor intensity, improve cleaning efficiency;
- Quick-connect design make it is easy and convenient to assemble and replace the frames and mop;
- The ergonomically designed handle has a comfortable grip and reduces operating fatigue.



Item No.	Name	Size	Color	PCS/CTN
6410	Alumium Handle	1350 mm	Silver	50

Ball Head Telescopic Aluminum Pole

- Made of lightweight aluminum alloy;
- Telescopic handle enables high place cleaning;
- Matching with the smooth connecting tip, it can realize the characteristics of a universal tool with one rod.



Item No.	Name	Size	Color	PCS/CTN
6420	Alumium Handle with Round Head	920-1600 mm	Grey	20

Mop product features

Headband type

Available in a variety of colors for use with the clip-on mop handle.

Yarn type

A variety of yarn options are available separately for use in different scenarios.

End type

Reduces wear, lint and looseness and is washable for longer life.

Tailband type



Productivity

By removing dirt and bacteria.



Health and welfare

Wet mopping products improve safety and reduce cross-contamination.



Sustainability

Make a positive impact on the environment with wet mops made from recycled materials.



Cost

Wet mopping products focus on short-term and long-term product durability, component quality, and reduction of user injuries.





Microfiber wet mops

- Constructed with a blend of microfiber and polyester;
- Provided superior absorbency and release characteristics;
- Tube design reduces drag for increased productivity;
- Anti-bacterial, premium launderability, Preshrunk for longer product life.



Item No.	Name	Size	Color	PCS/CTN
6600	Microfiber Wet Mops	155 mm	Blue(BU)	40

Cotton mop

- Excellent, all-purpose mop for general cleaning;
- Looped ends reduce fraying associated with Cut-end mops;
- Limited launderability, or hand wash up to 50 launderings.



Item No.	Name	Size	Color	PCS/CTN
6500	Cotton Mop	155 mm	WH, RD, BU, GN	24

Aluminum clamp-style Wet Mop Handles

- Thumbwheel clamps the mop firmly in place;
- Durable and light-weight handle;
- Mop handles make removing and replacing mop heads easy.

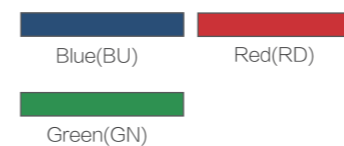

Item No.	Name	Size	Color	PCS/CTN
6400	Aluminum clamp-style Wet Mop Handles	1350 mm	RD, BU, GN	12



Clean and disinfect

The Centers for Disease Control and Prevention specifically states that "cleaning is the necessary first step in any sterilization or disinfection process." Disinfectants are most effective when in direct contact with the microorganisms they are trying to kill.



Spray bottle

- Suitable for all kinds of cleaning work, making the work easier and more effective;
- Resistant to acid, alkali and other chemical solvents;
- Sturdy HDPE spray bottle, strong and durable, even if bumped or dropped;
- Bottle with molded-in graduations;
- Ergonomic grip spray nozzle, comfortable in the hand and easy to operate.

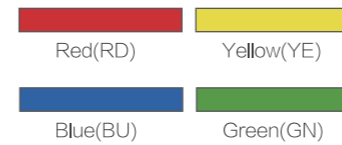

S600W

Item No.	Name	Capacity	Color	PCS/CTN
S600B	Spray Bottle	600 ml	White	100
SB	Spray Bottles – Spout	—	RD、BU、GN、YE	500
SW	Spray Bottle – Foam Spout	—	RD、BU、GN、YE	500

Spray bottle

- Thickened pot body, heat-resistant, not easy to aging and cracking;
- Copper nozzle, precision assembly, more durable than plastic nozzle, corrosion resistant;
- Humanized design, better grip.



Item No.	Name	Capacity	Color	PCS/CTN
PS1000	Spray Bottle	1000 ml	White	50
PS1500	Spray Bottle	1500 ml	White	50
PS2000	Spray Bottle	2000 ml	White	50



CLEANING



Microfiber cloths

Microfiber wipes are a powerful cleaning tool that combines high-quality microfiber and scraping strip technology. They are designed to effectively remove 99.7% of microorganisms and prevent the spread of infection. They come with complete functional accessories and are available in different colours to help users improve the cleaning process, minimize cross-infection, reduce the risk of disease by live pathogens, and improve cleaning efficiency. With these wipes, you can be sure that your cleaning process is efficient, safe, and effective.

- Provided best solution for cleaning tasks;
- Cloths withstand hundreds of launderings;
- Removes stains 30% more effectively than cotton cloths;
- Can remove 99.9% of microbes;
- Cleans effectively with less chemical replenishment.

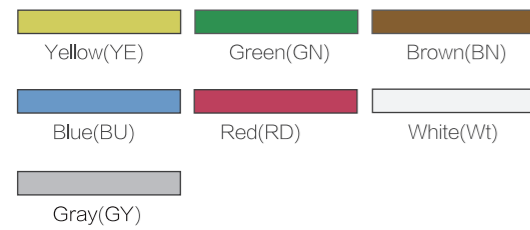

Item No.	Name	Size	Color	PCS/CTN
3030	Microfiber Cloths	300 × 300 mm	YE, GN, BN, BU, RD, WT, GY	250
4040	Microfiber Cloths	400 × 400 mm	YE, GN, BN, BU, RD, WT, GY	100
3070	Microfiber Cloths	300 × 700 mm	YE, GN, BN, BU, RD	150

Glass Cloth&Polishing Glass Cloth

- 100% microfiber, special weaving process;
- Extra smooth surface, glass and frame cleaning absolutely streak-free;
- Very good cleaning properties even without chemicals.
- Polyester brocade composition, strong water absorption;
- It is not easy to lose hair and does not leave water stains;
- Strong decontamination, good polishing effect.



2211

2212

Item No.	Name	Size	Color	PCS/CTN
2211	Glass Cloth	400 × 400 mm	BU	200
2212	Polishing Glass Cloth	400 × 400 mm	BU	500



Utility brush&floor scrub

Each location has different floor materials and dirt types, so it's necessary to choose the right broom and cleaning brush to improve cleaning efficiency. We provide you with brush heads and brushes to clean any floor.



Durable

Made of high-quality materials, it has a sturdy construction and can withstand frequent use and high intensity cleaning tasks.

Wet and dry use

Can be used on wet or dry surfaces. It can scrub tiles, floors, skirting boards, walls and kitchen countertops, etc.



CLEANING



Scrub brushes with handle

- PP fill;
- Plastic handle and durable;
- Easy to storage with the hang-up hole of handle.



Item No.	Name	Size	Color	PCS/CTN
1001	Scrub Brushes with Handle	65 × L150 mm	Yellow	12

Utility brush

- PP fill , designed to make scrubbing tile and cleaning floors;
- Plastic handle and durable;
- Easy to storage with the hang-up hole of handle.



1003



1002

Item No.	Name	Size	Color	PCS/CTN
1002	Tile and Grout Brush	250 × 14 × 40 × 15 mm	Yellow	250
1003	Utility Brush	77 × 230 mm	Yellow	12

Utility brush

- Fast to clean the counter;
- Plastic and durable handle;
- Easy to storage with the hang-up hole of handle;
- Long-lasting, stain-resistant PP bristles.



1004



1005

Item No.	Name	Size	Color	PCS/CTN
1004	Utility Brush	280 × 35 × 65 × 45 mm	Yellow	60
1005	Utility Brush	350 × 45 × 100 × 70 mm	Yellow	36

Long handle utility brush

- Fast to clean the counter;
- Plastic and durable handle;
- Easy to storage with the hang-up hole of handle;
- Long-lasting, stain-resistant PP bristles.



Item No.	Name	Size	Color	PCS/CTN
1006	Long Hnadle Utility Brush	410 × 45 × 75 × 35 mm	Yellow	12



CLEANING



Long handle utility brush

- Fast to clean the counter;
- Plastic and durable handle;
- Easy to storage with the hang-up hole of handle;
- Long-lasting, stain-resistant PP bristles.



Item No.	Name	Size	Color	PCS/CTN
1007	Long Handle Utility Brush	500 × 70 × 50 × 35 mm	Yellow	20
1008	Long Handle Utility Brush	77 × 500 mm	Yellow	20

Wire brush

- For efficient removal of rust, paint and grease;
- Handle has convenient hand hole;
- Long-lasting plastic handle.



Item No.	Name	Size	Color	PCS/CTN
G265	Wire brush	265 × 30 × 24 mm	Yellow	240

Floor scrub

- Tough plastic block will not crack, warp, or mildew;
- Long-lasting, stain-resistant PP bristles;
- Handles sold separately.



Item No.	Name	Size	Color	PCS/CTN
1127	Floor Scrub	270 × 65 × 100 × 35 mm	Yellow	31
1130	Floor Scrub	300 × 70 × 115 × 45 mm	Yellow	20
1147	Floor Scrub	470 × 70 × 115 × 45 mm	Yellow	28
1148	Floor Scrub	480x70x150x75 mm	Yellow	22

Floor scrub brush

- Flagged synthetic fibers help avoid scratching;
- Tough plastic block will not crack, warp, or mildew;
- Long-lasting, stain-resistant PP bristles;
- Handles sold separately.



Item No.	Name	Size	Color	PCS/CTN
1280	Floor Scrub Brush	77 × 240 mm	Yellow	12
1280T	Floor Scrub Brush Handles	1400 mm	Black	10



CLEANING



Pipe Exterior Brush

- Optimal length allows for more efficient and effective cleaning;
- Used to keep rounded exteriors free of dust and other contaminants;
- Handles sold separately.



Item No.	Name	Size	Color	PCS/CTN
1450	Pipe Exterior Brush	450 × 220 × 120 mm	Yellow	8

Broom Aluminum Handles

- Thread tips can be connected with brush and floor sweeps;
- Aluminum handles with comfortable design.

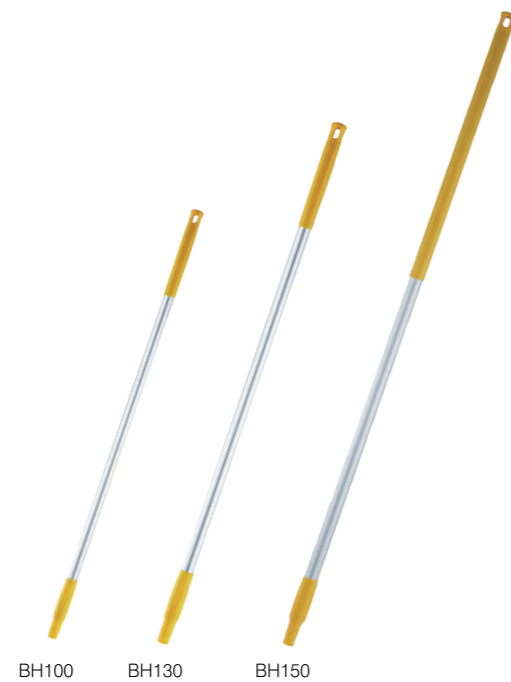

Item No.	Name	Size	Color	PCS/CTN
BH100	Broom Aluminum Handles	1000 × Φ28 mm	Yellow	30
BH130	Broom Aluminum Handles	1300 × Φ32 mm	Yellow	24
BH150	Broom Aluminum Handles	1500 × Φ32 mm	Yellow	24

Scrapers

- Heat treated carbon steel blade for maximum strength;
- Polished blade treated with a clear coat protectant against corrosion;
- Contoured handle helps reduce effort;
- Non-slip elastic handle offers a comfortable hold.



Item No.	Name	Size	Color	PCS/CTN
1300	Scrapers	235 × 50 × 25 mm	Yellow	250
1400	Scrapers	235 × 100 × 25 mm	Yellow	200

Scouring

- Ideal tool to clean bathtubs, tiles, sinks, barrels and covers;
 - Ideal tool to clean the floor, corner, and trace dirt;
 - Plastic scrapper assists in removing persistent and hard stains;
 - The bracket and pad are easily dismantled.
- Worn pads are replaceable.



Item No.	Name	Size	Color	PCS/CTN
1500	Scouring	230 × 95 × 80 mm	Yellow	20
1501-G	Pad	230 × 95 × 80 mm	Green	113
1501-W	Pad	230 × 95 × 80 mm	White	115

Scouring pad brushes optional with pole

- An ideal tool to clean bathtubs, tiles, sinks, barrels and covers;
 - An ideal tool to clean the floor, corner, and trace dirt;
 - Plastic scrapper assists in removing persistent and hard stains;
 - The bracket and pad are easily dismantled.
- Worn pads are replaceable;
- Can connect the aluminum pole to use.

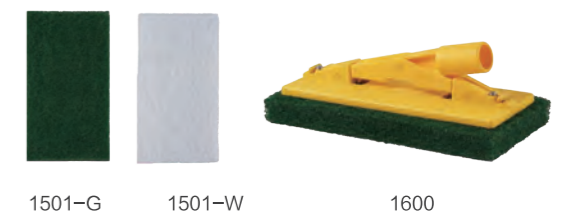

Item No.	Name	Size	Color	PCS/CTN
1600	Scouring Pad brushes optional with pole	230 × 95 × 80 mm	Yellow	30
1501-G	Replacement Cloth for Pepcid Mop	230 × 95 × 80 mm	Green	113
1501-W	Replacement Cloth for Pepcid Mop	230 × 95 × 80 mm	White	115



CLEANING



Diagonal broom & Diagonal broom Handles

- Ideal for hard-to-clean dead-end areas;
- Polypropylene bristles do not stain and have a long service life.



3180T



3180

型号	Name	Size	Color	PCS/CTN
3180	Diagonal broom	225 × 195 mm	Black	12
3180T	Diagonal broom Handles	750 mm	Black	12

Dust pans & broom

- Stylish appearance and an innovative design;
- Fit for applications such as a mall, canteen or lobby;
- Self-opening and closing lid conceals unsightly dirt and debris;
- Bracket for storage of Lobby Broom is available on the handle.



Broom clip, broom storage



The cover automatically opens when it is placed close to the ground and seals and odor-free when lifted.



3001-2

3001-1

Item No.	Name	Size	Color	PCS/CTN
3001-1	Dust pans	H900 mm	Black	10
3001-2	Broom	H900 mm	Black	20



CLEANING



Floor scraper & Rubber bar for Squeegees

- Thickened eva gel cotton, soft and wear-resistant;
- Thickened accessories, more durable;
- Replaceable adhesive cotton.

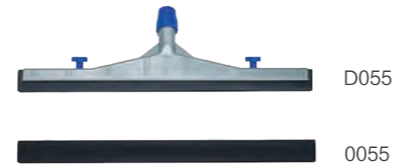

Item No.	Name	Size	Color	PCS/CTN
D045	18'Floor scraper	450 mm	Blue	20
D055	22'Floor scraper	550 mm	Blue	20
D075	30'Floor scraper	750 mm	Blue	20
0045	18'Rubber bar for Squeegees	450 mm	Ferrous	100
0055	22'Rubber bar for Squeegees	550 mm	Ferrous	100
0075	30'Rubber bar for Squeegees	750 mm	Ferrous	100

Floor scraper handle

- Lightweight aluminum alloy manufacturing, improve cleaning efficiency;
- ergonomic grip, comfortable, more comfortable control.



Item No.	Name	Size	Color	PCS/CTN
D135	Floor scraper handle	1350 × Φ25mm	Silver	50

Glass Squeegees with handle

- Stainless steel material, resistant to dirt corrosion;
- High-quality rubber strips, excellent abrasion resistance, scraping does not leave traces;
- Replaceable rubber strips.



Item No.	Name	Size	Color	PCS/CTN
B035	Glass Squeegees with handle	350 mm	Blue	100
B045	Glass Squeegees with handle	450 mm	Blue	100

Glass Squeegees with turning handle

- Copper bar quality, thick and beautiful, strong and durable;
- Locking type replacement rubber strip, more convenient.



Item No.	Name	Size	Color	PCS/CTN
W035	Glass Squeegees with turning handle	350 mm	Blue	100

Glass Squeegees

- Copper bar quality, thick and beautiful, strong and durable;
- Locking type replacement rubber strip, more convenient.



Item No.	Name	Size	Color	PCS/CTN
0106	Glass Squeegees	1060 mm	Ferrous	200
0106-1	Glass Squeegees	350 mm	Ferrous	30
0106-2	Glass Squeegees	450 mm	Ferrous	20

Microfiber dusters

- Microfiber material, with a collection of stain removing and water absorbency;
- Replaceable brush cover, can be used repeatedly after cleaning.



Item No.	Name	Size	Color	PCS/CTN
C060	Microfiber dedusting rod	600 mm	Grayish Blue	50
C005	Microfiber dedusting rod sleeves	500 mm	Grayish Blue	100



CLEANING



Coral Fleece DUSTERS

- Coral fleece material, excellent water absorption;
- Thickened material, more durable;
- Replaceable hair head.



Item No.	Name	Size	Color	PCS/CTN
T035	Applicator	350 mm	Yellowish White	Bracket 100 a box Sleeve 100 a box
T035-1	Applicator Replacement Hair Sleeve	350 mm	Yellowish White	100

Glass cleaning Scraper & Blade For Scraper

- Thick material, high strength blade;
- Convenient replacement blades, suitable for smooth connection system.
- Stainless steel blade, sharp and wear-resistant, sturdy and not easy to deform;
- Boxed design, easy to carry and organize.



Item No.	Name	Size	Color	PCS/CTN
6622	Glass cleaning Scraper	220 × 100 mm	Grey	100
0010	Blade For Scraper	100 mm	Silver	200

Telescopic aluminum rod

- High strength aluminum alloy material, strong and durable;
- Internal lock design, different from the market external lock, stretching more labor-saving;
- Match with the smooth connecting tip, can realize one rod universal tool characteristics.



Item No.	Name	Size	Color	PCS/CTN
S180	Telescopic aluminum rod	1000-1800 mm	Silver	30
S240	Telescopic aluminum rod	1330-2400 mm	Silver	30

Ball head three-section

- High strength aluminum alloy material, strong and durable;
- Internal lock design, different from the market external lock, stretching more labor-saving;
- Match with the smooth connecting tip, can realize one rod universal tool characteristics.



Item No.	Name	Size	Color	PCS/CTN
S360	Ball head three-section telescopic rod	1410-3600 mm	Black	20

Three-section telescopic rod

- Telescopic buckle, adjust the required length, adjust to the required length and then tighten it;
- The surface of the handle is textured with a non-slip design.



Item No.	Name	Size	Color	PCS/CTN
S600	Three-section telescopic rod	6000 mm	Silvery	24
S900	Three-section telescopic rod	9000 mm	Silvery	24

Side Clamp Mop Bar

- Rotary disassembly, rotate it to loosen it, it can be easily disassembled and installed;
- Preferred material, acid and alkali resistance, corrosion resistance, not easy to break.



Item No.	Name	Size	Color	PCS/CTN
C6400	Side Clamp Mop Bar	1400 mm	Yellow	24



CLEANING



Bath mats

- Suction-backed to stay firmly in place;
- Latex-free construction;
- Textured surface prevents slippage;
- Mildew-resistant.

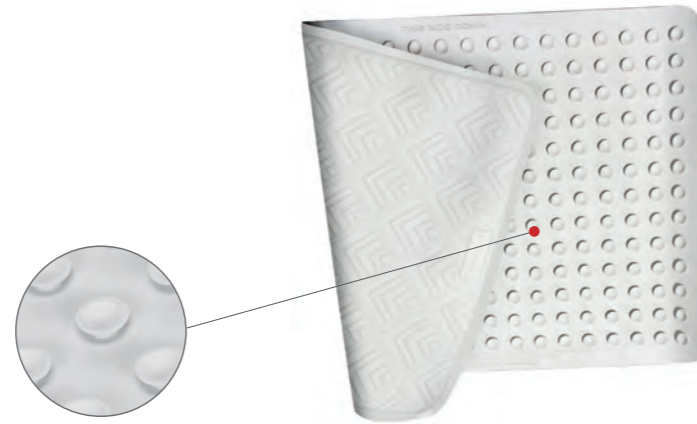

Item No.	Name	Size	Color	PCS/CTN
2052	Bath mats	360 × 570 mm	White	16

Wool duster

- 100% Wool Duster, fluffy and soft hair feel to enhance the dusting effect;
- The rod can be adjusted in length for a larger cleaning range.



Item No.	Name	Size	Color	PCS/CTN
1251	Wool duster	830–1100mm	Black	50

Overhead Dusting Tools

- Extended pole body of various layer heights can easily cope with;
- Verdikt staafmateriaal is sterk en duurzaam, corrosiebestendig;
- Double joint design, rotary cleaning does not leave dead ends;
- Enlarged panel, large area cleaning efficiency.

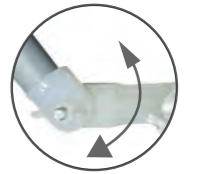

Rotary cleaning leaves no dead space



Item No.	Name	Size	Color	PCS/CTN
AC130	Overhead Dusting Tools	100–130cm	White	20

Wall cleaning tools

- Thickened aluminum rod material;
- Velcro sticking method, more convenient to replace the cloth cover;
- Enlarged panel, high cleaning efficiency for large area.



Item No.	Name	Size	Color	PCS/CTN
WCT18	Wall cleaning tools	Cloth 205 × 380mm Pole length 1000–1800mm	White	24

Utility Box

- Thick material, square shape and easy to clean;
- Curved rounded corners for better sense of use, large capacity is the ideal container for storage.



Item No.	Name	Size	Color	PCS/CTN
2812	Utility Box	510 × 380 × 160mm	Grey	12

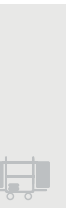

CLEANING

Cutlery Bin 4 Compartments

- Thickened material, lattice partition design, better classification storage knife and fork and other various tableware and seasoning packets, etc., is the ideal container for storage.



Item No.	Name	Size	Color	PCS/CTN
2664	Cutlery Bin 4 Compartments	535 × 290 × 95mm	Grey	12

Toilet Bowl Brushes and Holders

- Stain- and odor-resistant;
- Extended Handle;
- Material pp+ps;
- Small hole at the end of the handle for hanging and easy storage.



Item No.	Name	Size	Color	PCS/CTN
M4233	Toilet Bowl Brushes and Holders	420 × 135 mm	White	12

Round Buckets

- Material pp;
- heavy duty wall thickness, sturdy, strong and durable;
- rounded appearance, make the scale more accurate;
- Comfortable plastic handle makes it easier to lift the bucket;
- Handle position at the bottom, easier to pour water;
- Stackable, saving storage space;
- with scale line, more accurate blending, improve efficiency.



Item No.	Name	capacity	Size	Color	PCS/CTN
RB15	Round Buckets	15 L	φ 305 × 290 mm	Dark Gray	10

Double buckets

- Material pp;
- sturdy, strong and durable;
- Rule appearance, make the scale more accurate;
- comfortable plastic handles for easy lifting of buckets;
- Separate fresh water and sewage;
- stackable, saving storage space.



Easily recognizable scales



Item No.	Name	capacity	Size	Color	PCS/CTN
DB22	Double buckets	22 L	370 × 460 × 250 mm	Grey	10

Bathtub Brush

- Thick, soft bristles, no glaze damage
- Delicate, soft, abrasion-resistant and durable.
- Easier to clean with a single rinse.
- Ergonomic handles for a comfortable grip



Item No.	Name	Size	Color	PCS/CTN
BB312	Bathtub Brush	300 × 120 mm	White	100

Extruded Toilet Brush & Soft Bristle Toilet Brush

- Soft texture, does not hurt the glaze of the toilet bowl
- Squeeze toilet brush with a cap to squeeze the water out after cleaning without getting your hands dirty.
- Hanging hole storage design, does not take up space



Item No.	Name	Size	Color	PCS/CTN
STB45	Extruded Toilet Brush	45cm	White	50
SBTB46	Soft Bristle Toilet Brush	45cm	White	50



Cleaning carry caddy

- Perfect for carrying tools or cleaning supplies;
- User-friendly handle fits your hand and provides a comfortable grip;
- Allows for stable stacking to save space.

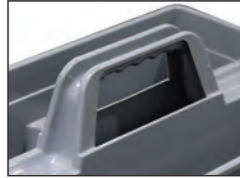

Ergonomic handle design provides comfortable fit



Made of durable impact-resistant plastic to ensure product durability



Heavy-duty caddy conveniently fits



Item No.	Name	Size	Color	PCS/CTN
C1015	Cleaning Carry Caddy	386 × 275 × 170 mm	Gray	6

Tool holder kit

- Helps increase productivity and efficiency through better tool storage and access;
- Rubber soft clip hold 1.6cm to 3.2cm diameter handles;
- Aluminum alloy material, lightweight and rust-proof.

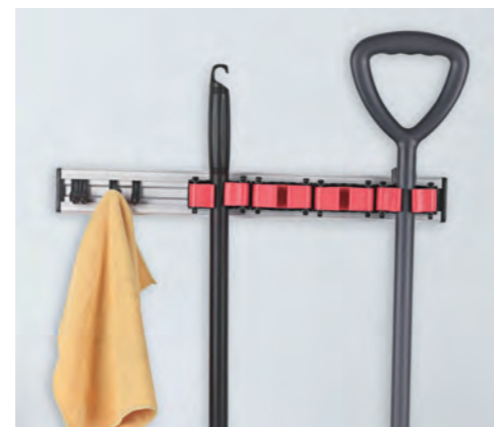

Item No.	Name	Size	Color	PCS/CTN
THK	Tool Holder Kit	462 × 55 × 60 mm	Silver	24
THK71	Tool Holder Kit	710 × 55 × 60 mm	Silver	12

Mobile step stool

- Heavy-duty stepstool glides on retractable rubber casters;
- Supports loads up to 350 lbs;
- Soft, slip-resistant pads on both steps;
- Wheels retract when stepped on;
- Heavy-duty plastic construction minimizes damage to walls and furniture.



Item No.	Name	Size	Color	PCS/CTN
MSS	Mobile Step stool	φ406 x 343 mm	Black	3

Folding Step stool

- Easy to carry, and foldable;
- With thickened plastic, features four skid-resistant foot pads and it is rust and dent resistant, this 2 step ladder;
- The small step stool foldable has anti-slip grooves on the treads and dense anti-slip texture on the rubber pads.



Item No.	Name	Size	Color	PCS/CTN
FSS	Folding Step stool	490 x 580 mm	Grey	2



CLEANING



Mop bucket

The anti-splash mop bucket and wringer system reduces splashing providing a safer environment, cleaner floors, and improved productivity. High-efficiency wringer, wrings mop with 18% less effort. Made of premium tubular steel and structural web molded plastic to ensure higher durability and toughness.



Assembly required

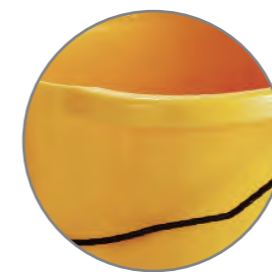

Durable

Thickened engineering plastic, the barrel body does not deform and is more durable

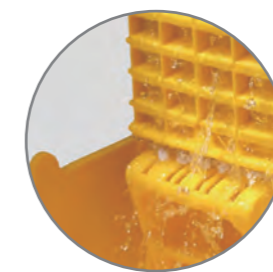

Squeeze water easily

Enlarge the water squeezing basket, squeeze water with strong force, use it easily and conveniently, and mop the floor better



Bigger bucket body

More water storage improves cleaning efficiency



CLEANING



Easily squeezed out 80% Water

Retain about 20% of the water, mop the floor just right to clean the mop without getting your hands dirty.



Mop bucket

- Made of premium tubular steel and structural web molded plastic to ensure higher durability and toughness;
- Ergonomically designed handle fit your hands and height, and reduce the need for bending;
- Removable and non-marking wheels reduce the clean job.



Any mop width below 20cm can be used



Item No.	Name	Size	Color	PCS/CTN
MOP32	Mop bucket	540 × 380 × 900 mm	Yellow	1

Caution floor sign

- Foldable design for easy storage, minimizing space;
- Built-in hooks for hanging heavy objects;
- Customizable imprints.



A-frame

The a-line style can be installed quickly and easily in areas with damp floors. Can be folded up when not in use.



Easy to transport

There is a handle on the top of the sign to make it easy to pick up the sign for added convenience.



Item No.	Name	Size	Color	PCS/CTN
CFS01	Cleaningin Progress	298x20x620 mm	Yellow	10
CFS01	Wet Floor	298x20x620 mm	Yellow	10
CFS01	Out Ofservice	298x20x620 mm	Yellow	10



Spills happen unexpectedly, creating hazards for patrons and staff which need to be cleaned up as quickly as possible to avoid injuries. Using a string mop and bucket can be time-consuming and leaves the floor wet. Over-the-Spill Pads make it easier to cover and absorb spills while simultaneously alerting pedestrians to potential slip-and-fall hazards.

Three million

Catering waiter Injuries caused by falls and slips every year

11,000

fatal slip happens every year in hospitals

Injuries are increasingv

10%



CLEANING



Janitor cart

- An ideal solution for collecting trash and transporting cleaning tools to effectively increase cleaning efficiency;
- Smooth surface for easy cleaning;
- Zipped waste bags assist in emptying of waste;
- 20cm non-marking wheels and 10cm non-marking castors enhance maneuverability;
- A complete system solution with integrated holders for various tools to cater for your cleaning.



Assembly required



Can insert different tools such as screwdriver and pliers.



Large platform
Front platform holds mop bucket.

Zippered trash bag
Zippered trash bags for easy dumping

Casters
Two swivel casters allow you to maneuver and turn in small spaces

Item No.	Name	Size	Color	Metric Capacity	PCS/CTN
JC03	Janitor Cart	1140 × 510 × 980 mm	Black	100 kg	1

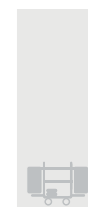

Multifunctional cleaning cart

- Mop bucket storage platform;
- Foldable platform for sterilization buckets;
- Innovative rubber tool grip secures handle in any position.



Assembly required

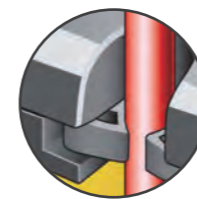

Rubber tool clip

Large platform
Front platform holds mop bucket.

Zippered trash bag
Zippered trash bags for easy dumping



4" swing casters

8" directional casters

Item No.	Name	Size	Color	Metric Capacity	PCS/CTN
JC02	Multifunctional Cleaning Cart	1212 × 575 × 1115 mm	Black	100 kg	1



CLEANING



Luxury cleaning cart

This product has a stylish and luxurious appearance that can blend well with various indoor environments. It can boost the morale of cleaning staff and enhance the corporate image. It has a sturdy structure, and the frame can endure high weight and pressure, ensuring stability and durability in various work scenarios. The device has multiple functions, allowing cleaning staff to organize various cleaning supplies, improve work efficiency, and simplify maintenance tasks while minimizing turnaround time.

- ▶ Large capacity, small footprint;
- ▶ Rubber tool clips on front and rear;
- ▶ Optional two 30-quart storage buckets can be installed on either side of the cart;
- ▶ Two 10-quart disinfection buckets are optional, each of which can carry 6 sprayers;
- ▶ Comes with locking cabinet door, locking safety cover and storage box.



Cleaning cart function

Smart, stylish cleaning solutions designed to enhance your image and increase employee efficiency



Quiet casters

Silent caster design, rolling more smoothly and reducing noise. Enable employees to work discreetly around guests.



Storage Box

Provides waste coverage and offers functional storage for small items.



Locking hood

Ensures secure storage for critical items



CLEANING



Luxury cleaning cart

This luxury cleaning cart is ergonomically designed for easy operation and maximum comfort, and is waterproof and chemical-resistant for easy maintenance and long-lasting quality. For maximum convenience, it features replaceable handles and a removable platform, allowing users to easily remove or reduce the cart's footprint to meet specific cleaning and storage needs. The cart features ergonomic handles, ball bearing wheels and quiet casters for smooth, seamless movement.



Assembly required



Item No.	Name	Size	Color	Metric Capacity	PCS/CTN
JC05	Luxury Cleaning Cart	1212 × 575 × 1320 mm	Black	100 kg	1



TRANSPORTATION OF STORED PRODUCTS

MATERIAL HANDLING

Built to last with industry-leading durability

Product Material Handling Solutions Enhanced
Increase productivity and improve safety in virtually any commercial facility.
Designed for Material Handling Professionals
Products offer superior ergonomics, organization, reliability and
Actionability that transforms any job into a more productive one.



Cube Trucks
For various usage scenarios such as linen transportation, material collection and cargo transportation



Heavy-Duty Utility Cart
Sturdy structure, transportable materials and strong load-bearing capacity



Heavy-duty Platform Trucks
Efficiently transport bulky cargo



Mobile Step stool
Supports loads up to 350 lbs; Wheels retract when stepped on



-
-
-
-
- MATERIAL HANDLING**
-



Cube truck

- Integrated molding design, smooth surface, easy to clean;
- It can be used in various use scenarios such as linen transportation, material collection and cargo transportation;
- Two universal wheels and two directional wheels;
- The requirement for in-situ rotation can be achieved.



Function

Housekeeping solutions designed to improve staff efficiency.



Swivel casters

Equipped with universal wheels, the vehicle can rotate in place, making it easier to operate and move.



Large capacity

Improve work efficiency, reduce the number of round-trip transportation, and save time and labor costs.

Item No.	Name	Size	Capacity	Color	Metric Capacity	PCS/CTN
CT12-B	Cube truck	1070x740x860 mm	339L	Black	180 kg	1
CT12-W	Cube truck	1070x740x860 mm	339L	White	180 kg	1



Collapsible laundry cart



This compact, foldable linen cart is perfect for hotels, hospitals, and guesthouses. It has a heavy-duty canvas bag holding much bedding or dirty laundry. This helps to save facility space. Electroplated stainless steel frame to help prevent rust; and the "X" frame design allows the bag to be fully opened for easy access. This product makes working in various environments easier for your cleaning crew.

The cart also allows you to classify materials, preventing cross-contamination. The premium swivel casters and bumper guards also ensure that you can move the cart without worrying about marking the walls. With this linen cart, you can ensure your facility is efficient and organized.



Folding design

Compact, collapsible frame reduces width by 75% to enable efficient storage.



MATERIAL HANDLING



Collapsible laundry cart

- Compact, light, and collapsible. It enable efficient storage, with large capacity, durable and reusable;
- Detachable, easy to clean up;
- Black lacquer covers up stains and dirt;
- High-quality TPR casters move quietly;
- Rubber bumper guard help prevent damage.



Item No.	Name	Size	Capacity	Color	Metric Capacity	PCS/CTN
CLC150	150L Collapsible Laundry cart	660x495x860 mm	150L	Black	100 kg	1
CLC300	300L Collapsible Laundry cart	895x660x860 mm	300L	Black	100 kg	1
CLC300X	300L Classified Folding Fabric Cart	895x660x860 mm	300L	Black	100 kg	1
BAG150	150L Replacement bag	335x560x750 mm	150L	Black	—	15
BAG300	300L Replacement bag	730x560x750 mm	300L	Black	—	10



X-Type Fabric Cart

- Large space and large capacity;
- The frame structure can be retracted freely for more space;
- Adopting high quality steel with thicker and thickening;
- Universal wheel is more flexible, front and back, left and right to change the direction of more flexible;
- Made of high quality Oxford cloth bag material.



Item No.	Name	Size	Color	PCS/CTN
TLC-X	X-Type Fabric Cart	800x500x880 mm	Black	1

Fabric storage cart

- Large storage space, easy to operate;
- Selection of high-quality steel manufacturing
- Stable structure;
- Encrypted mesh to prevent small items from falling out;
- High-quality casters are used for better wear resistance.



Four-side impact resistant rubber design reduces Damage to the car body due to collision



cryptographic lattice

Handle is easy to push

Lockable design prevents cargo from falling

Metal shelves

Universal wheel, front and back, left and right at will Change direction more flexible



Item No.	Name	Size	material	PCS/CTN
LSC800	150L Collapsible Laundry cart	800x800x1820 mm	stainless steels	1
LSC650	300L Collapsible Laundry cart	1050x540x1700 mm	iron baking paint	1

Utility cart with side panel

Ideal for restaurants, hotels, cleaning staff, catering staff and more, this service cart is a reliable way to transport a variety of items. Whether you need to transport food trays back and forth between buffets or sort dirty cutlery and china in plastic buckets, this three-tier service cart with a 136KG capacity can meet your transportation needs. Three-sided enclosures can also be used to hide items, giving it a neat and clean appearance.

- ▶ Light and flexible, ideal for hotels, restaurants and bars;
- ▶ Can be used to collect and carry food or table wares in room service;
- ▶ PP material is environmental, sanitary, durable and easy to be cleaned;
- ▶ Three-tier design provides enough space for storage;
- ▶ Bear capacity: 136 KG;
- ▶ With more convenient open top layer;
- ▶ Ergonomically designed handle can be comfortably and flexibly used;
- ▶ Optional with half open and full open.



Features

Smart, stylish cleaning solutions effectively enhance work appearance and improve employee efficiency.



Quiet casters

Silent casters rotate flexibly and have excellent controllability. Equipped with two lockable casters to ensure stability when loading and unloading cargo.



Side panels can be installed

Three enclosed sides help prevent spills while in use and also serve to hide items.



Aluminum columns with strong load-bearing capacity

The carrying capacity of 136 KG can meet your transportation needs.

Utility cart with side panel

Ideal for front-of-house and back-of-house storage, this beautiful and durable utility cart can easily transport dinner plates, plates, cups, cutlery and more. With a sleek design that can be used by anyone, this cart is ideal for any crowded restaurant, cafeteria, or catered event.



UC02



UC01



RB09



RB30

Item No.	Name	Size	Color	Metric Capacity	PCS/CTN
UC02	Utility cart with side panel	980x530x930 mm	Black	136 kg	1
UC01	Utility cart Open-sided	980x530x930 mm	Black	136 kg	1
RB09	Refuse bin 15L	330x230x178 mm	Black	/	6
RB30	Refuse bin 30L	330x230x560 mm	Black	/	6



Tri-fold room service cart

- Ultra-strong load-bearing, sturdy and durable
- Silent rubber wheels
- 3-fold design to protect vehicle stacking. Reduced space requirements



Folding Storage



Wide countertop design, the countertop is spacious and comfortable. Place all kinds of objects and tableware as you like

Selected high-quality stainless steel material, corrosion-resistant. Not easy to rust, not easy to deform

Holds holding tank rails

360° flexible steering, vibration damping and quiet effect is obvious

Five-Fold room service cart

- Ultra-strong load-bearing, sturdy and durable
- Silent rubber wheels
- 5-fold design to protect vehicle stacking. Reduced space requirements



Folding Storage



Wide countertop design, the countertop is spacious and comfortable. Place all kinds of objects and tableware as you like

The main pipe is thickened stainless steel round tube

Stainless steel square tube holding tank brackets are solid and durable

Double-sided warming box placement structure. Convenient and time-saving

360° flexible steering, vibration damping and quiet effect is obvious

Item No.	Name	Size	Color	PCS/CTN
RST3F	Tri-fold room service cart	1100x915x750 mm	Black	1

Item No.	Name	Size	Color	PCS/CTN
RST5F	Five-Fold room service cart	1070x910x745 mm	Black	1

Food Warmer Caddy Storage Trolley

- Knock-down trolley easy to assemble
- 6 plugs with fuse and switch
- 6 places for hot box storage
- Silent wheel with brake



Item No.	Name	Size	Color	PCS/CTN
WBT16	Food Warmer Caddy Storage Trolley	870x440x1600 mm	Black	1

Food Warmer Caddy

- Stainless steel double-layer structure
- Metal powder coating surface treatment
- Effective thermal insulation
- Insulation box door carrying lock device



WB3F



WB5F



Item No.	Name	Size	Color	PCS/CTN
WB3F	Food Warmer Caddy	380x390x510 mm	Black	1
WB5F	Food Warmer Caddy	380x370x480 mm	Black	1

Heavy-duty utility cart

This multi-purpose tool cart can transport materials, supplies and heavy loads in most environments! The multi-tool cart is constructed from solid structural foam for maximum durability, with a choice of sunken or flush platforms and a wide platform for oversized items. The integrated V-shaped notch can safely secure tubular objects, and the deeper embedded tool slot ensures the safety of items; the ergonomically designed handle height is more comfortable to use, improving maneuverability and worker safety.

- ▶ Transport materials, supplies, and heavy loads securely in almost any environment;
- ▶ Durable structural foam construction won't leak, rust, chip, dent, or peel. Available in pocket-shelf or flat-shelf models;
- ▶ Deep pocket shelves to keep loads secure;
- ▶ Ergonomic handle allows optimum hand placement for improved worker safety and control;
- ▶ Molded-in fittings allow you to add pipe or rods to hold supplies and roll goods.



Features

Transport materials, supplies, and heavy loads securely in almost any environment.



Stay organized

Easy-reach tool/accessory hooks provide additional storage.



Work more efficiently

Built-in tool holster and caddy keep items at hand and in place during transport.



Customizable

Molded-in fittings allow you to add pipe or rods to hold wire spools and other roll-type goods.



MATERIAL HANDLING



Heavy-duty utility cart



Assembly required

Integrated V-notch to hold pipe and conduit securely for safe cutting

Variable grip-height handle improves control and worker safety.

Molded-in fittings allow you to add pipe or rods to hold supplies and roll goods.

Durable structural foam construction won't leak, rust, chip, dent, or peel.

Keep loads secure
Deep pocket shelves keep contents in place



HUC3416



HUC4324

Item No.	Name	Size	Color	Metric Capacity	PCS/CTN
HUC3416	Heavy-duty Utility Cart	875x425x827 mm	Black	250 kg	1
HUC4324	Heavy-Duty Utility Cart With Handle	1095x625x970 mm	Black	250 kg	1



Heavy-Duty Platform Truck

Ideal for moving large, heavy, oversized loads in a variety of environments from retail to construction.

- Suitable for transportation of heavy and bulky objects in any environment;
- ergonomic handrails for easy maneuvering and improved worker safety;
- cast structure, strong and durable, improve the durability of the trolley, increase the service life. Increase service life;
- surface texture treatment, increase anti-slip performance, improve the safety of transporting objects.



Retainer clips prevent unintended handle removal.

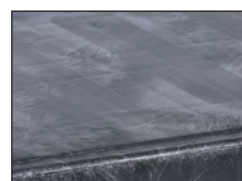

A sturdy, plastic textured deck prevents loads from moving during transport, and it will not rust, dent, crack, chip, peel

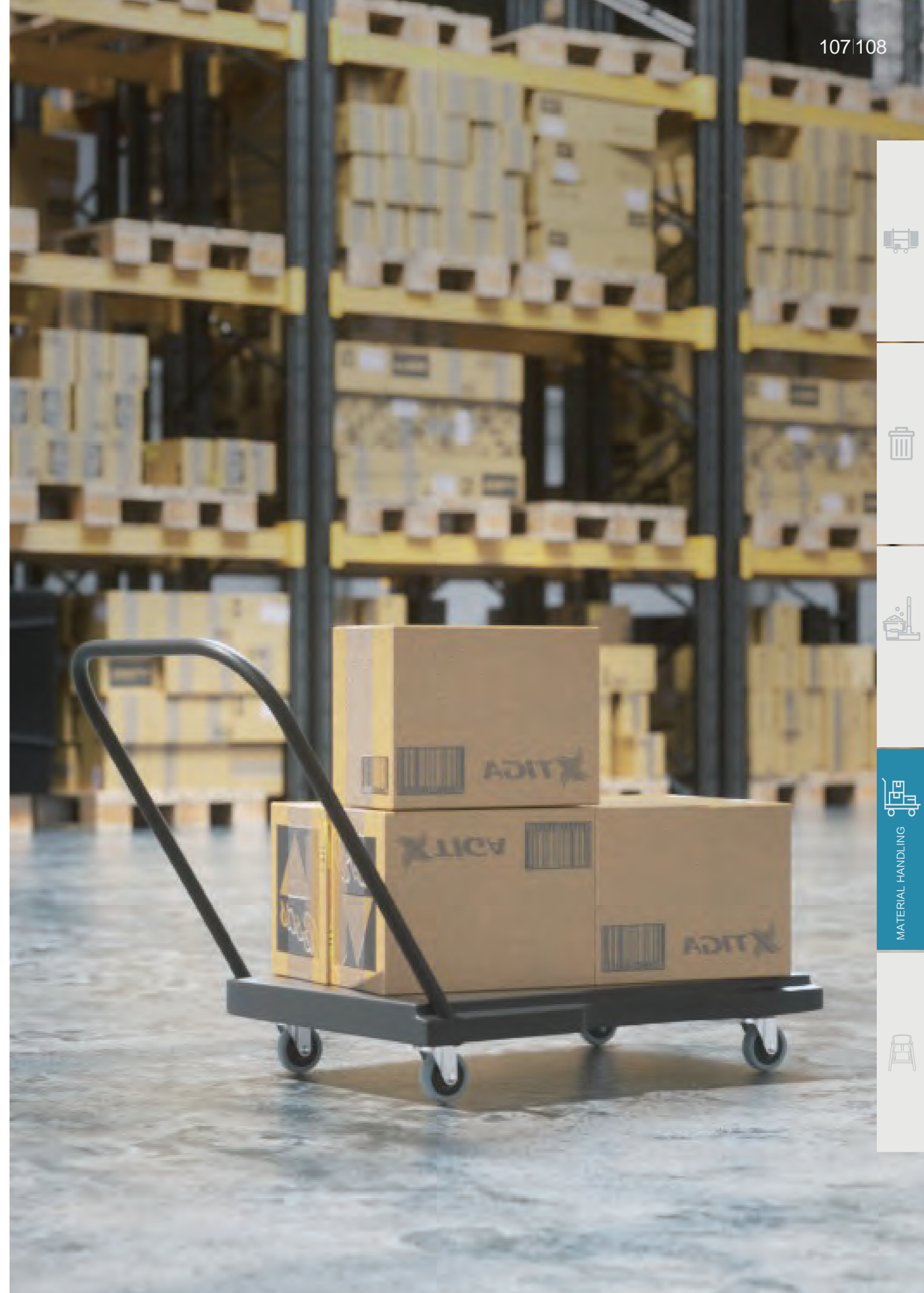

Item No.	Name	Size	Color	Metric Capacity	PCS/CTN
HF960	Heavy-Duty Platform Trucks	914x610 mm	Grey	500 kg	1



MATERIAL HANDLING



Platform truck

- Efficiently transports large, bulky loads, then folds flat for easy storage;
- Sturdy structural foam deck won't rust, dent, chip, or peel;
- Nonskid platform surface helps prevent load shifting;
- Three-position handle lets users push, pull, or fold flat for use as a dolly;
- Casters are nonmarking.

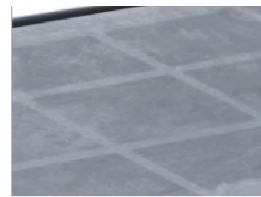

Nonskid platform surface helps prevent load shifting



Notch design on both sides makes it easy to carry when folded

Powder-coated steel creates a hard finish that is far tougher than conventional paint.



Item No.	Name	Size	Color	Metric Capacity	PCS/CTN
PT01	Platform truck	800x520x880 mm	Grey	200 kg	1



1094110



TRANSPORTATION AND STORAGE



Baby changing station

- PP material Safety and health;
- Hydraulic rod design folds, opens and closes gently;
- Storage box design multi-functional storage;
- Safety belt design avoid accidental falling.



Can hang personal belongings

Storage table for convenient placement of baby care products

Storage units at the top of the table are convenient to place baby care products.

High side guardrail design



Wide table is equipped with adjustable seat belts enhancing safety and reliability.

Item No.	Name	Size	Color	PCS/CTN
BCS	Baby Changing Station	870x550x500 mm	Grey	1



Baby high chair

- The design has taken a full consideration of the capacity and stability;
- The matched tray can be used conveniently;
- It can be taken down with one hand;
- Stackable design makes for easy storage.



Stackable Design



Tray



Meets the ASTM F404-16 safety standards



National standard, American standard safety inspection report

Permanent t-bar restraint
T-bar must remain in fixed position at all times.

Easy to clean

Convenient handle for safe, one-handed maneuvering throughout dining room.



Active three-point restraint
An active three-point restraint system is required.

Item No.	Name	Size	Color	Metric Capacity	PCS/CTN
BHC01	Baby high chair	590x640x740 mm	Grey	30 kg	1